

Schematic	Altera A406 KFB		Update Date	
Page			Create Date	
Drawn			Part Number	
Reviewed			A406_KFB	
	VER	SIZE	PAGE	1 OF 4
思妙电子				

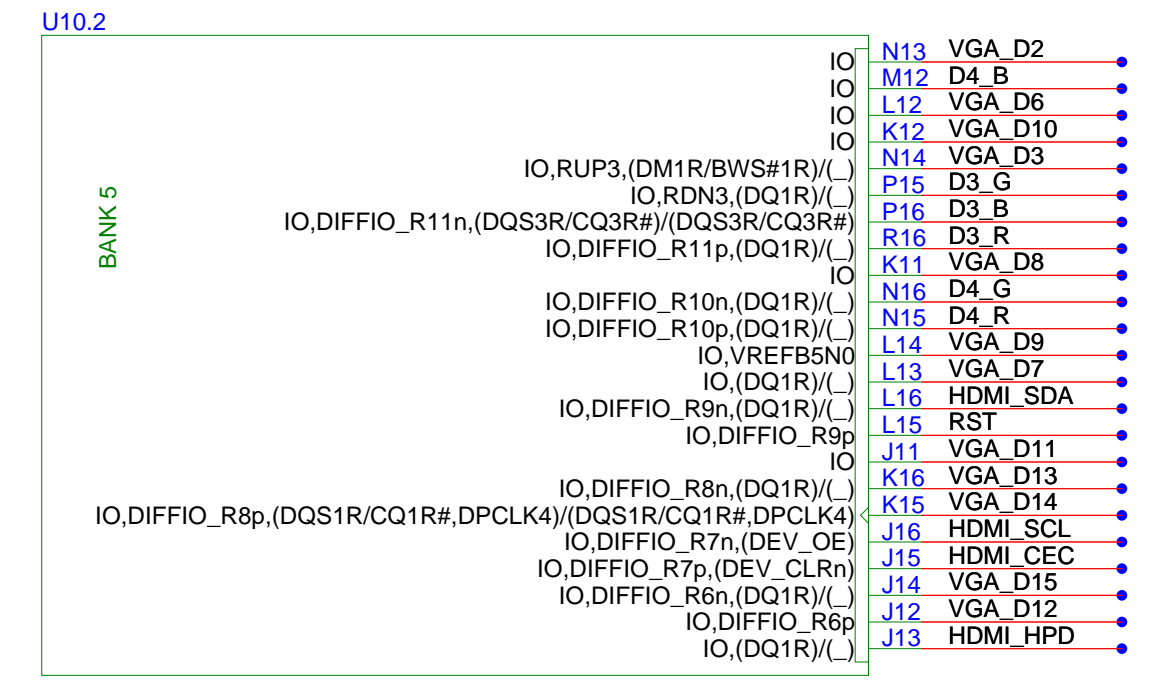

Schematic	Altera A406 KFB		Update Date	
Page			Create Date	
Drawn			Part Number	
Reviewed			A406_KFB	
思妙电子		VER	SIZE	PAGE 2 OF 4

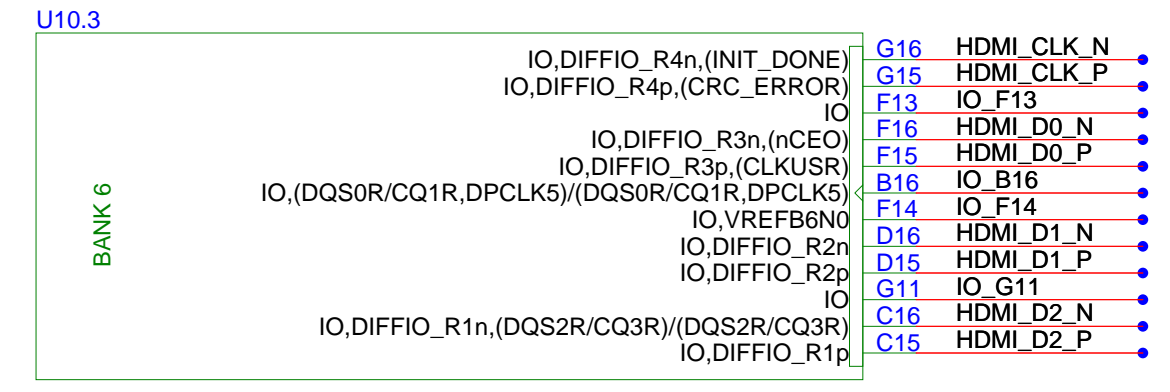
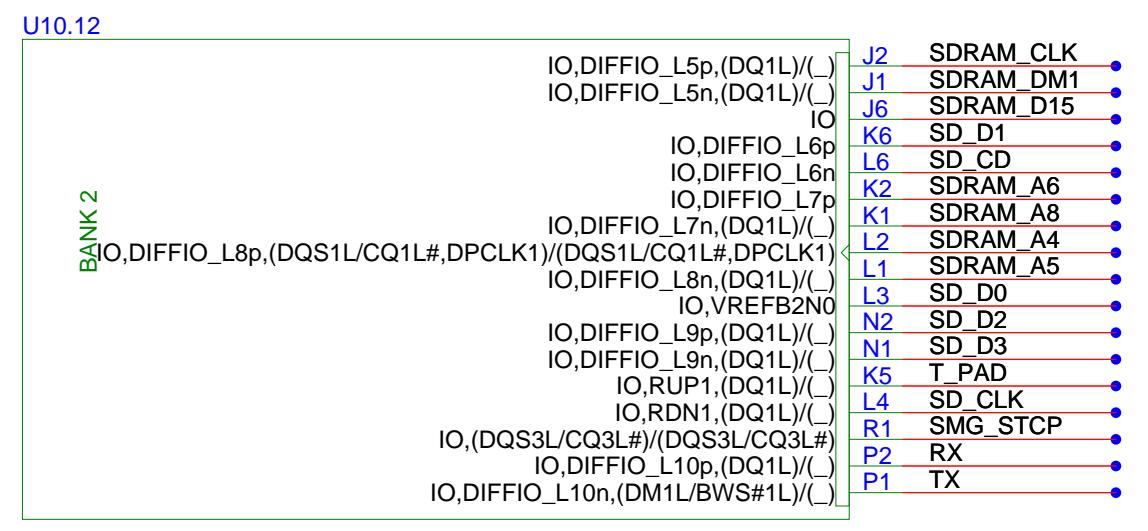
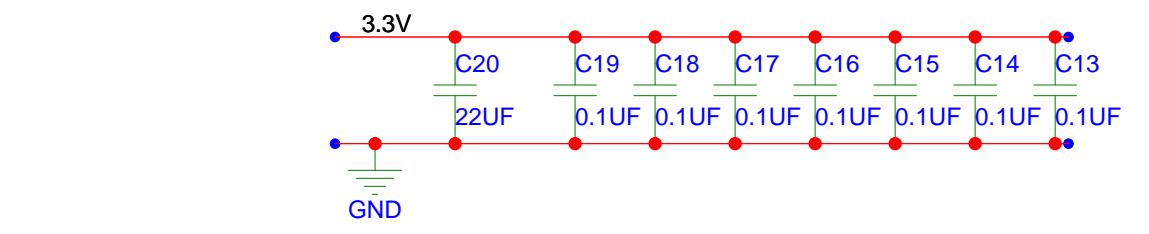
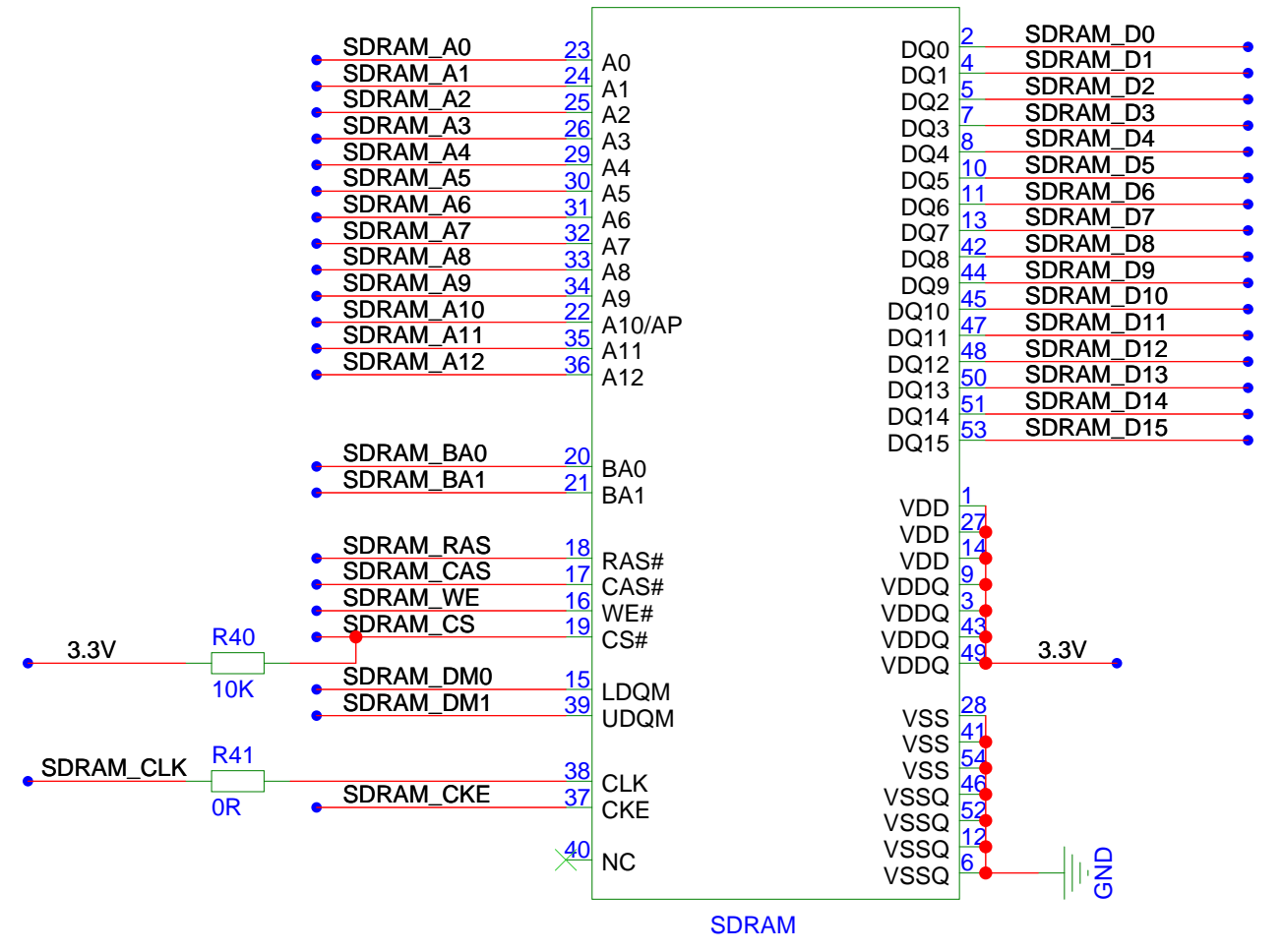
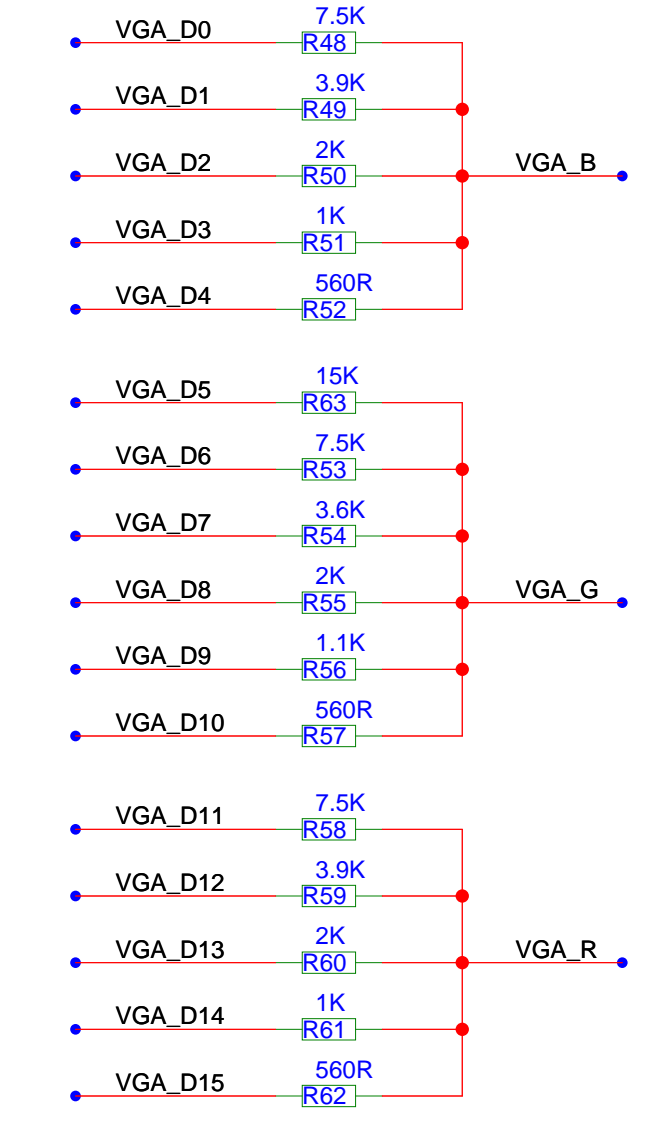
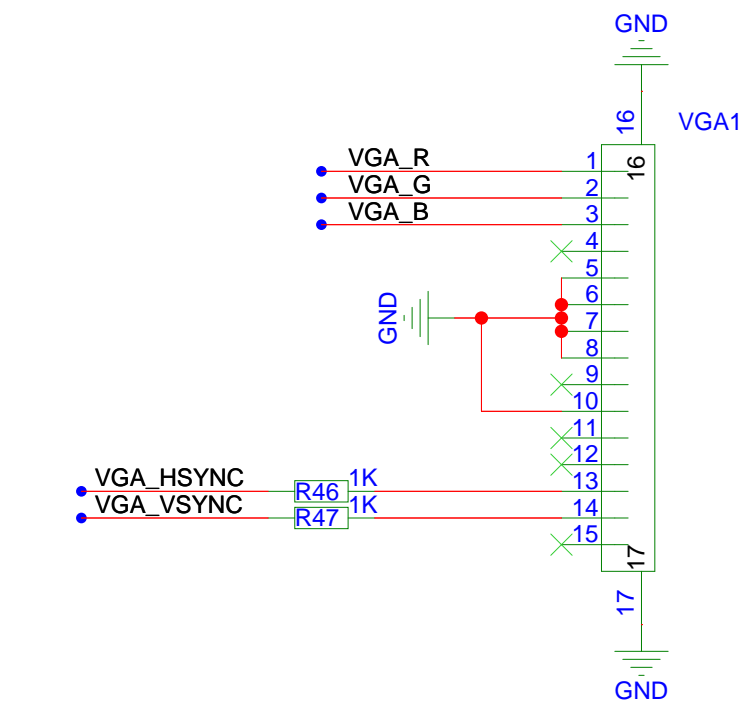
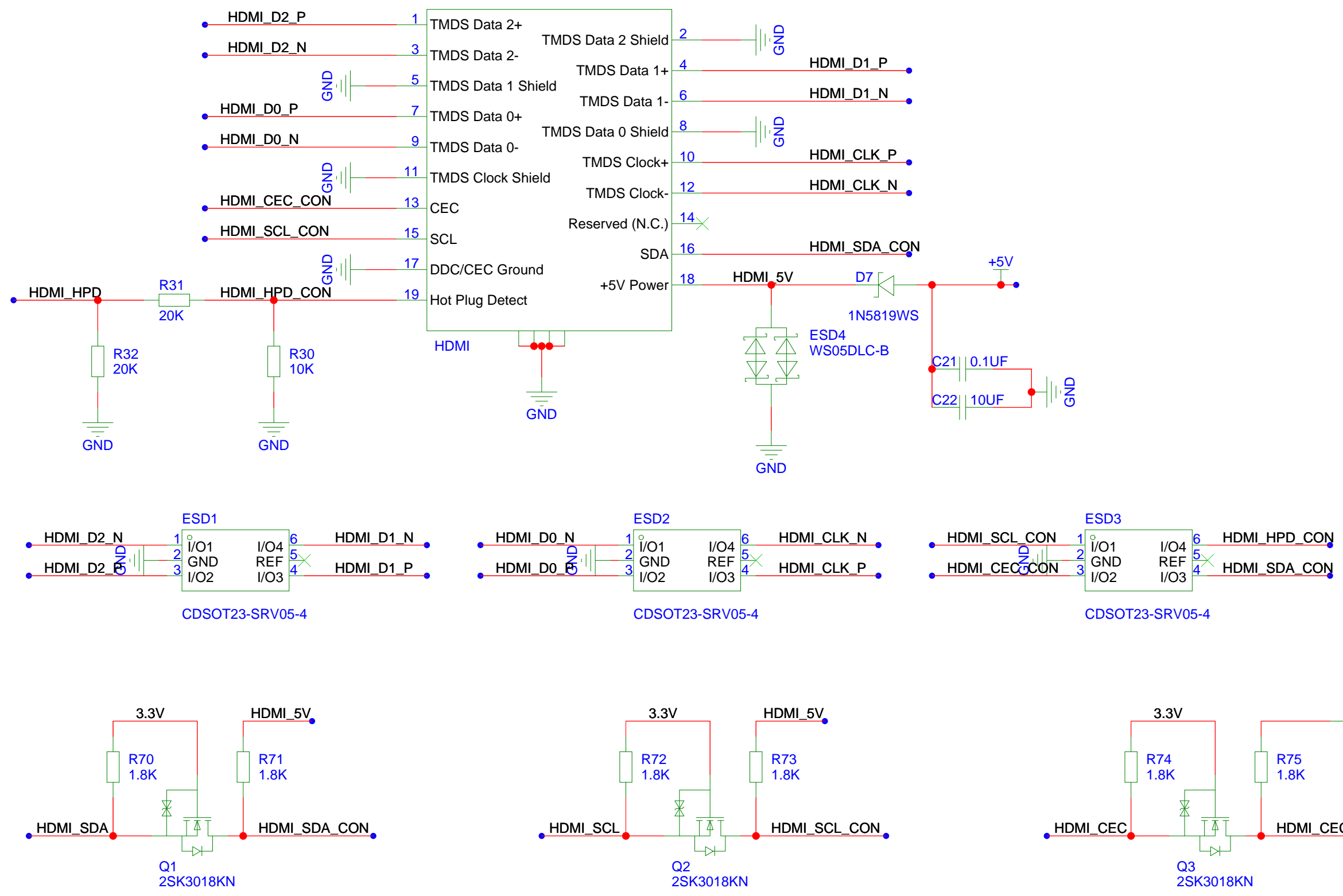

Schematic	Altera A406 KFB			Update Date	
				Create Date	
Page				Part Number	
Drawn				A406_KFB	
Reviewed					
思妙电子				VER	
				SIZE	
				PAGE	3 OF 4

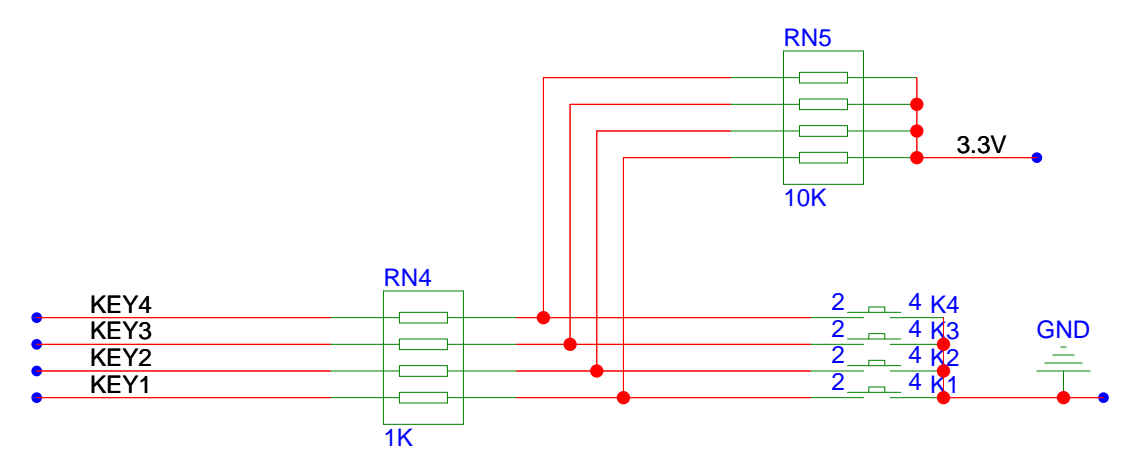
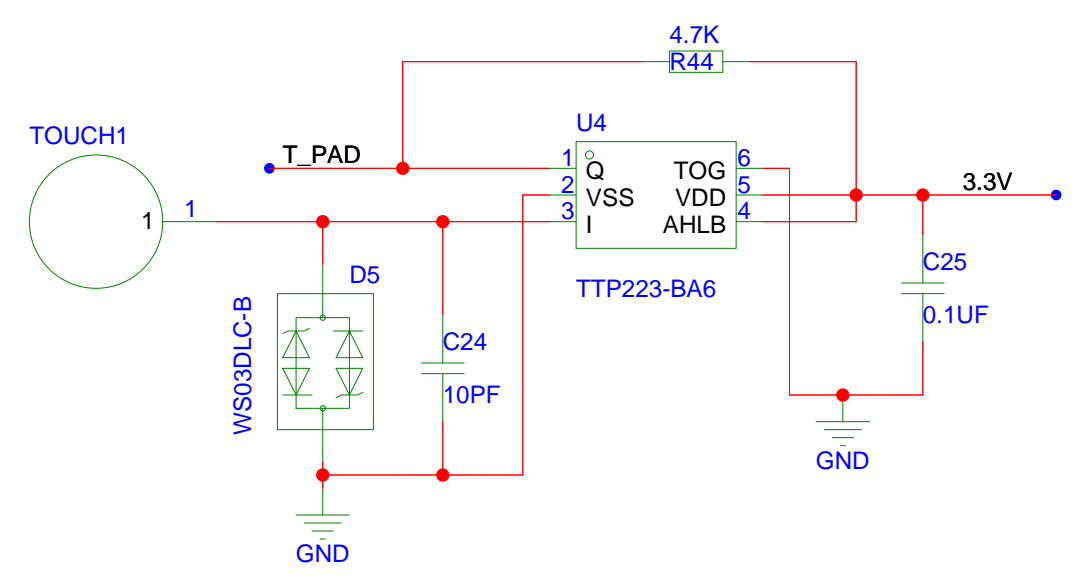
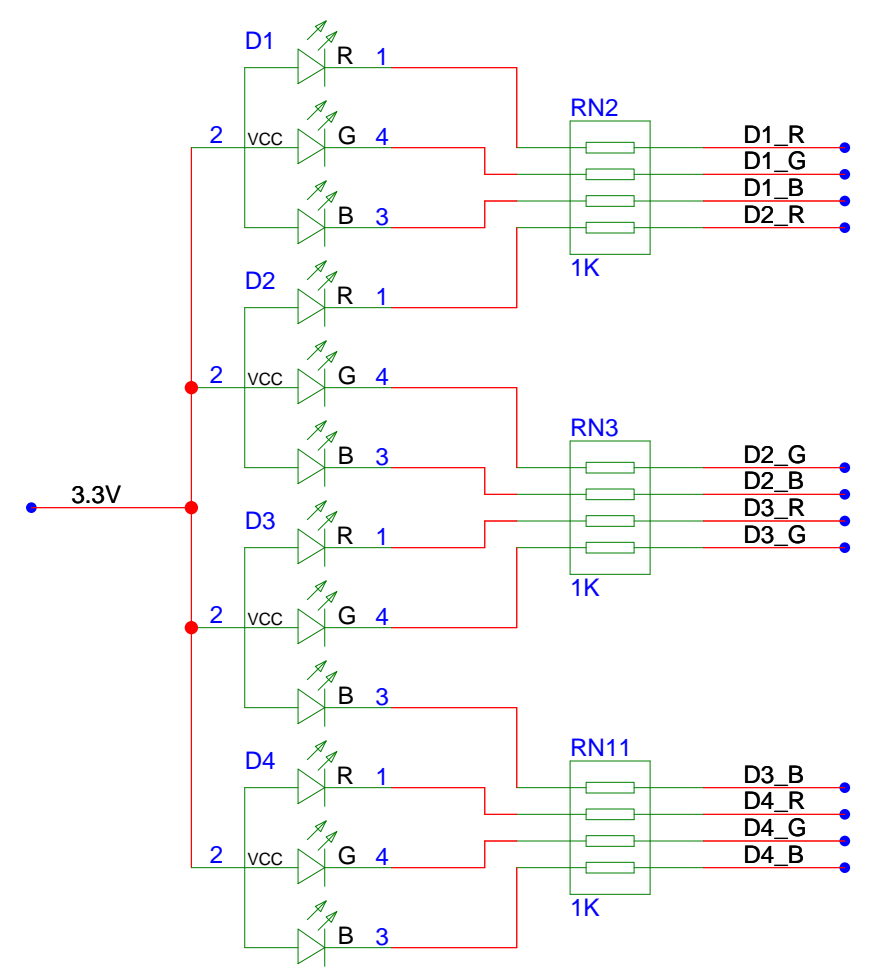
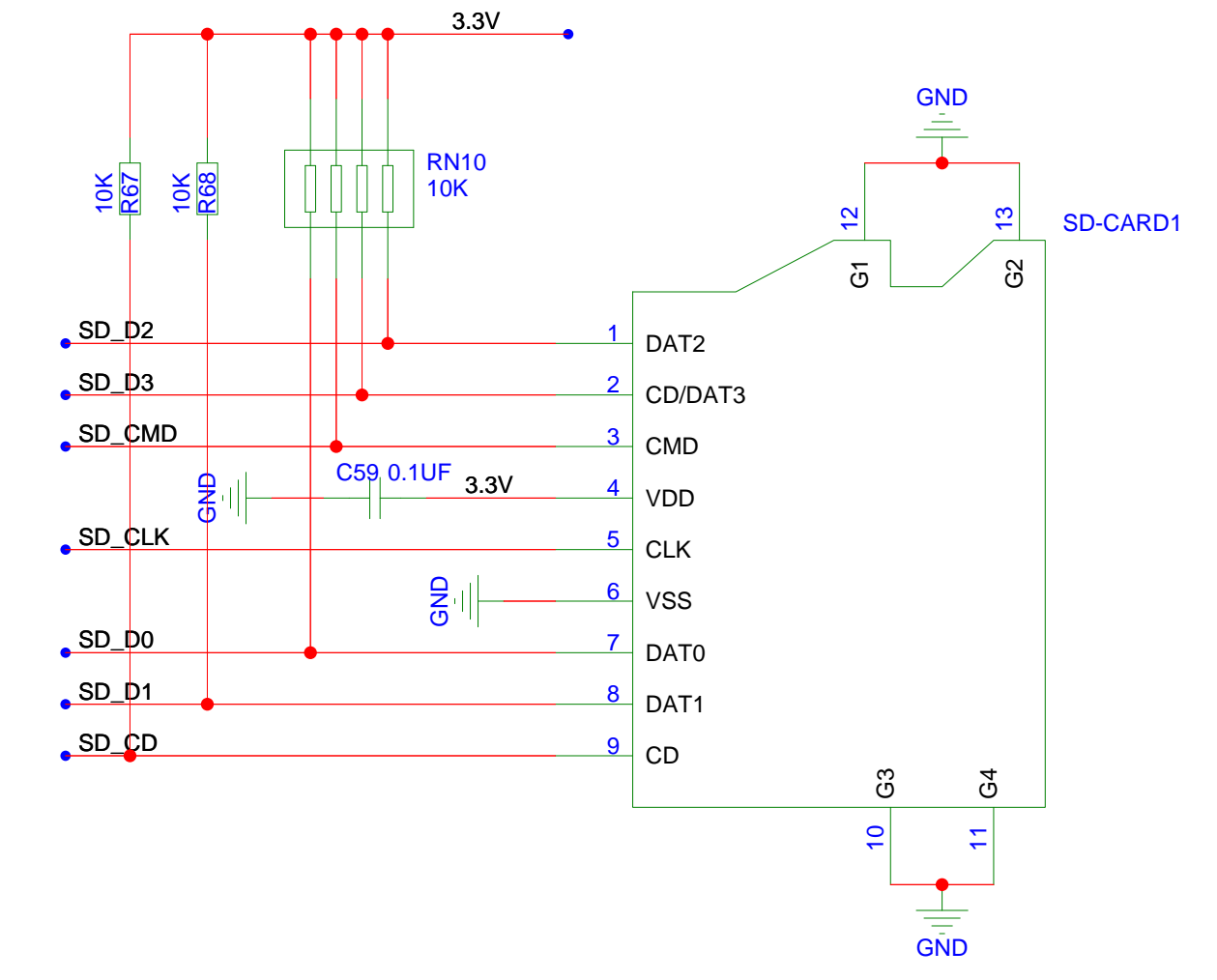
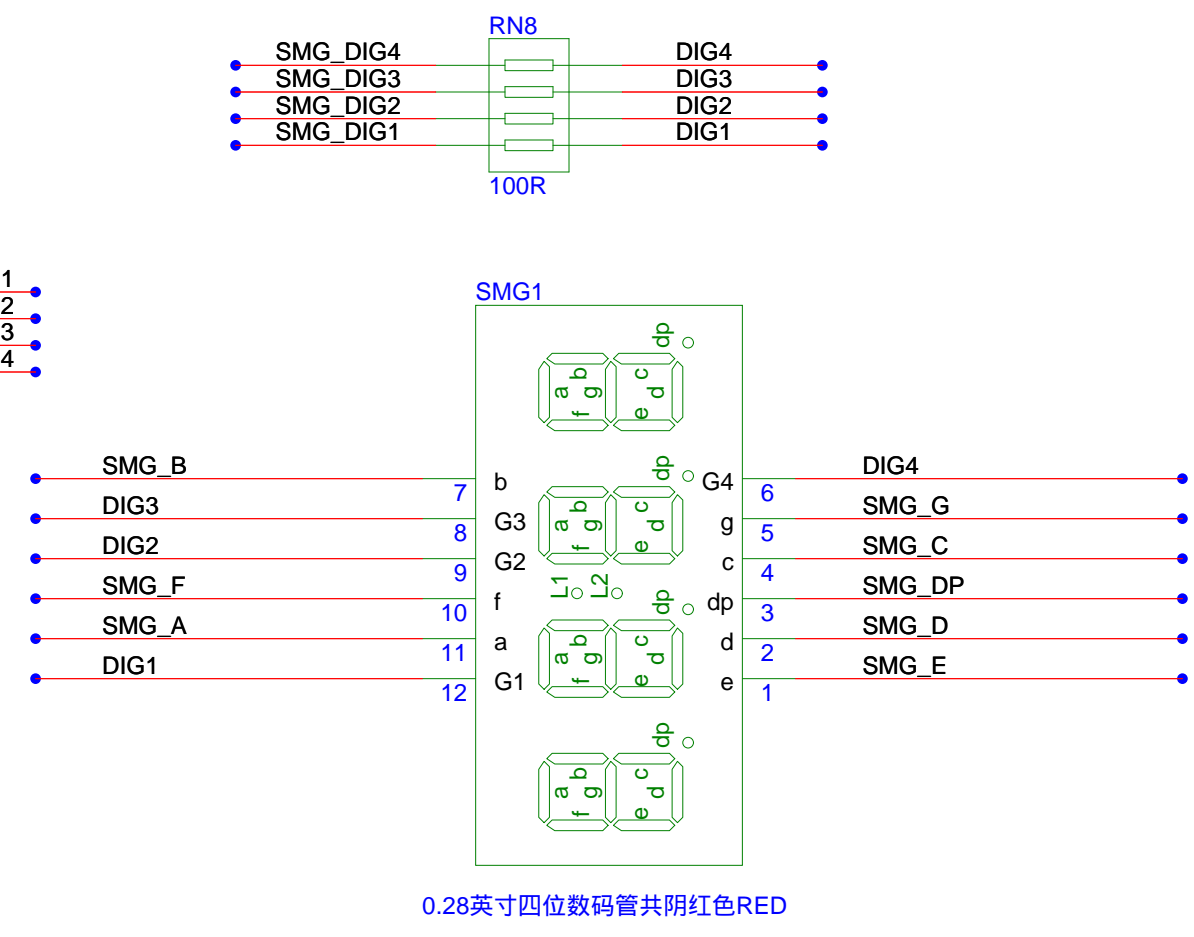
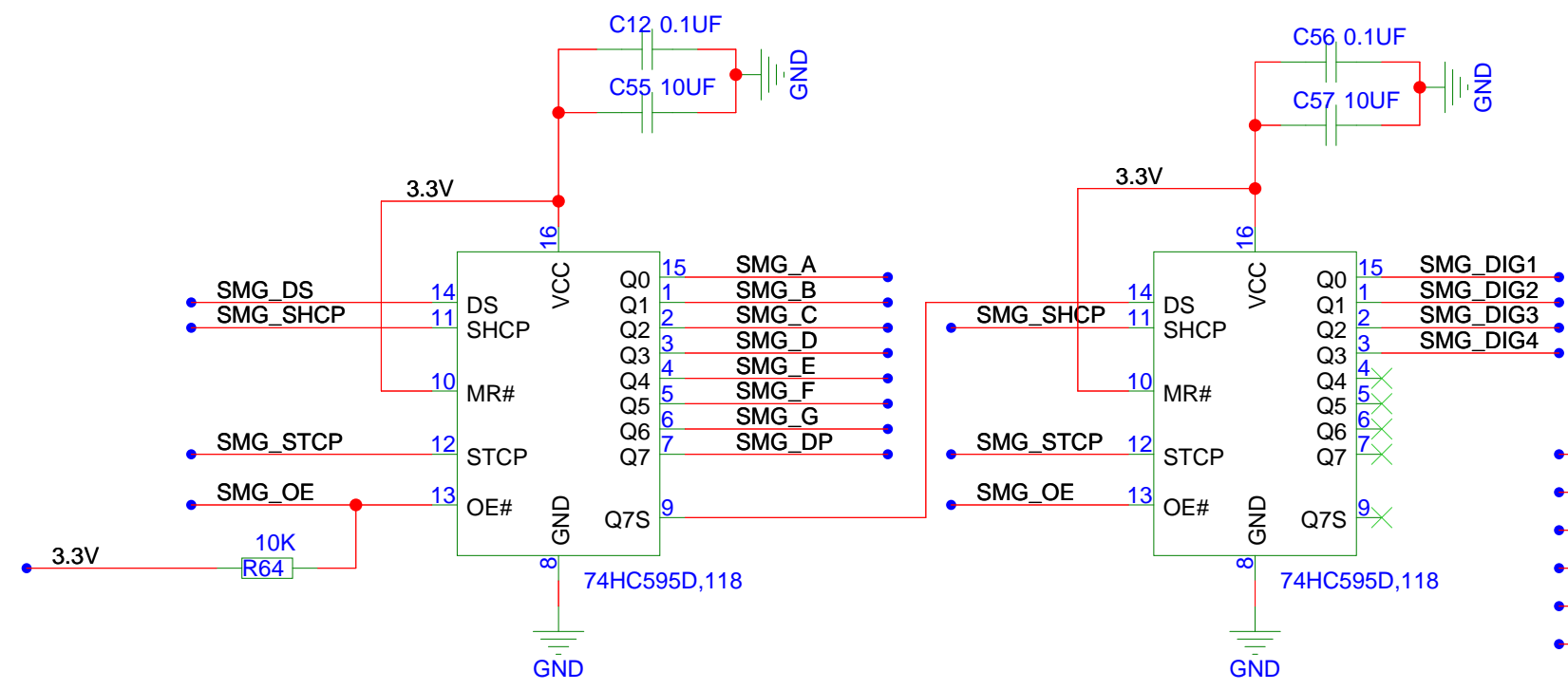

Schematic	Altera A406 KFB			Update Date	
Page				Create Date	
Drawn				Part Number	
Reviewed				A406_KFB	
思妙电子		VER	SIZE	PAGE 4	OF 4